

Control of Three-Level Bidirectional Buck-Boost Converter for Battery Energy Storage System in Bi-Polar DC Microgrid

Dr. K. Thenmalar¹, Professor, Department of Electrical and Electronics Engineering,

Vivekanandha College of Engineering for Women, Tiruchengode, thenmalar@vcew.ac.in.

Harshini P², Department of Electrical and Electronics Engineering, Vivekanandha College of Engineering for Women, Tiruchengode, harshinip800@gmail.com.

Keerthana M³, Department of Electrical and Electronics Engineering, Vivekanandha College of Engineering for Women, Tiruchengode.

Pavithra N S⁴, Department of Electrical and Electronics Engineering, Vivekanandha College of Engineering for Women, Tiruchengode.

Varneshwari R⁵, Department of Electrical and Electronics Engineering, Vivekanandha College of Engineering for Women, Tiruchengode.

Abstract :

This paper presents the control and performance analysis of a three-level bidirectional buck-boost converter integrated with a battery energy storage system (BESS) in a bi-polar DC microgrid. The proposed system enables bidirectional power flow between renewable energy sources, DC loads, and the battery system while maintaining voltage balance across the bi-polar DC bus. A model predictive current control strategy is employed to achieve fast dynamic response, reduced voltage imbalance, and improved power quality under varying source and load conditions. Simulation results demonstrate the effectiveness of the proposed control scheme in regulating DC-link voltages and ensuring stable microgrid operation.

Keywords: Three-level bidirectional converter, Buck–boost DC–DC converter, Battery energy storage system, Bi-polar DC microgrid, Bidirectional power flow, DC bus voltage regulation, Converter control strategy, Voltage balancing control, Energy management, Power electronics for microgrids.

1. Introduction

The rapid growth of renewable energy sources (RES) such as solar photovoltaic (PV) and wind energy systems has significantly influenced the evolution of

modern power systems. DC microgrids have gained considerable attention as an effective solution for integrating distributed energy resources due to their high efficiency, reduced conversion stages, and ease of interfacing with DC-based sources and loads.

Compared to conventional unipolar DC architectures, bi-polar DC microgrids provide several advantages, including improved reliability, reduced conductor losses, enhanced voltage utilization, and flexible power distribution under asymmetric loading conditions. Despite these advantages, the intermittent and stochastic nature of renewable energy generation presents significant challenges in maintaining power balance and voltage stability within DC microgrids. Variations in generation and load demand can lead to DC bus voltage fluctuations, which may compromise system performance and reliability. To mitigate these issues, battery energy storage systems (BESS) are widely employed as key components to absorb surplus energy and supply power during generation deficits. Efficient and reliable power electronic interfaces are therefore essential to enable controlled bidirectional power flow between the battery system and the DC microgrid. Three-level bidirectional DC–DC converters have emerged as a promising topology for BESS integration in bi-polar DC microgrids. Compared with conventional two-level converters, three-level converters offer reduced voltage stress across power semiconductor devices, lower switching losses, improved efficiency, and enhanced power handling capability. Additionally, the multilevel structure facilitates better voltage sharing and supports balanced operation of the positive and negative DC buses. However, effective control strategies are required to ensure stable operation, accurate DC bus voltage regulation, and smooth transitions between charging and discharging modes under varying operating conditions. Three-level

bidirectional DC–DC converters have emerged as a promising topology for BESS integration in bi-polar DC microgrids. Compared with conventional two-level converters, three-level converters offer reduced voltage stress across power semiconductor devices, lower switching losses, improved efficiency, and enhanced power handling capability. Additionally, the multilevel structure facilitates better voltage sharing and supports balanced operation of the positive and negative DC buses. However, effective control strategies are required to ensure stable operation, accurate DC bus voltage regulation, and smooth transitions between charging and discharging modes under varying operating conditions.

2. Literature Review

DC microgrids have emerged as a promising architecture for integrating renewable energy sources, energy storage systems, and DC loads due to their high efficiency and reduced power conversion stages. Several studies have highlighted the advantages of bi-polar DC microgrids over unipolar configurations, including improved reliability, enhanced voltage utilization, and reduced conductor losses under unbalanced load conditions. These benefits make bi-polar DC microgrids particularly suitable for modern distributed power systems with diverse energy resources and loads. Battery energy storage systems (BESS) play a critical role in mitigating the intermittency of renewable energy sources and ensuring power balance in DC microgrids. Various power electronic interfaces have been proposed for connecting batteries to DC buses, with bidirectional DC–DC converters being the most widely adopted solution. Conventional two-level

bidirectional buck–boost converters have been extensively studied due to their simple structure and ease of control. However, their applicability in high- power and high-voltage DC microgrids is limited by increased voltage stress on switching devices, higher losses, and reduced efficiency. To overcome these limitations, multilevel bidirectional DC–DC converter topologies have been introduced. Among them, three-level converters have gained significant attention owing to their reduced voltage stress, lower switching losses, and improved power density. Neutral-point-clamped (NPC) and flying capacitor-based three-level converters have been explored for BESS integration in DC microgrids. These converters also offer improved output voltage quality and better suitability for bi- polar DC architectures. However, maintaining voltage balance between the positive and negative DC buses remains a key challenge, especially under asymmetric loading conditions. Several control strategies have been proposed to regulate bidirectional power flow and maintain DC bus voltage stability. Conventional proportional– integral (PI) control schemes are widely used due to their simplicity and robustness. Advanced control methods such as model predictive control, sliding mode control, and adaptive control have also been investigated to improve dynamic performance and robustness against parameter variations. While these techniques enhance system response, they often increase computational complexity and implementation cost. Despite significant progress, existing literature reveals gaps in achieving coordinated control of three-level bidirectional converters for BESS in bi-polar DC microgrids, particularly in ensuring

voltage balance, smooth mode transitions, and stable operation under varying renewable generation and load conditions. Therefore, further research is required to develop efficient control strategies that combine simplicity, reliability, and high performance for practical DC microgrid applications.

3. Methodology

A three-level bidirectional buck–boost DC–DC converter is used to interface the battery energy storage system with the bi-polar DC microgrid, enabling controlled bidirectional power flow. The converter operates in buck mode for battery charging and boost mode for battery discharging to maintain power balance and DC bus voltage stability. A closed-loop control strategy with voltage and current regulation is implemented to ensure stable DC bus voltage and balanced operation of the bipolar rails. The proposed system is modeled and simulated under varying load and renewable generation conditions to evaluate voltage regulation, dynamic response, and overall performance.

4. Existing System

In existing DC microgrid systems, unipolar DC architectures combined with two-level bidirectional buck–boost DC–DC converters are commonly used for integrating battery energy storage systems. These converters are favored for their simple topology and ease of control; however, they suffer from high voltage stress on power semiconductor devices, especially in high-voltage applications. The conventional control approaches, typically based on PI controllers, exhibit limited performance under rapid load variations and unbalanced operating

conditions. As a result, issues such as reduced efficiency, increased switching losses, and DC bus voltage imbalance persist, making existing systems less suitable for reliable and efficient operation in bi-polar DC microgrids.

5. Proposed System

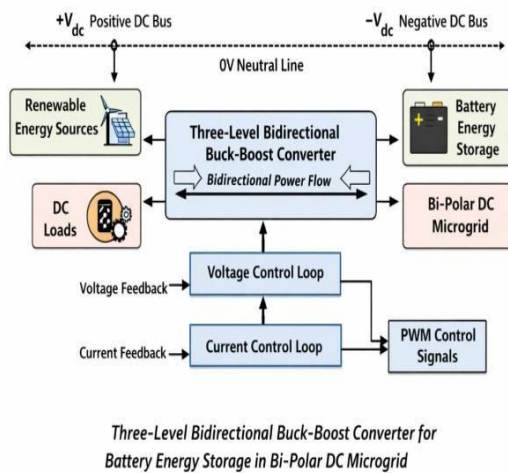

Figure 1: Block Diagram

The proposed system incorporates a three-level bidirectional buck–boost DC–DC converter to interface a battery energy storage system with a bi-polar DC microgrid. The converter enables controlled bidirectional power flow, allowing the battery to charge when there is excess renewable generation and discharge to support the DC bus during power deficits. The three-level topology reduces voltage stress on switching devices, minimizes switching losses, and improves overall system efficiency compared to conventional two-level converters. A closed-loop control strategy is employed to regulate the DC bus voltage and maintain voltage balance between the positive and negative rails, ensuring stable microgrid operation under varying load and renewable generation

conditions. Additionally, the control scheme provides smooth transitions between charging and discharging modes and supports reliable energy management. The performance of the proposed system is evaluated through simulation, demonstrating improved voltage regulation, dynamic response, and efficient bidirectional power transfer, making it suitable for modern bi-polar DC microgrids.

6. System Design

The system is designed to integrate a battery energy storage system (BESS) with a bi-polar DC microgrid consisting of renewable energy sources, loads, and a three-level bidirectional buck–boost DC–DC converter. The bi-polar DC microgrid has positive and negative rails with a neutral point, which improves voltage utilization, reduces conductor losses, and enhances reliability under unbalanced load conditions. Renewable sources, such as solar photovoltaic (PV) panels and wind turbines, are connected directly to the DC bus through suitable power electronic interfaces, supplying power to the loads and the BESS.

The three-level bidirectional converter serves as the interface between the DC bus and the battery. It allows power to flow in both directions: in buck mode, it charges the battery from excess renewable generation; in boost mode, it discharges the battery to support the DC bus during generation deficits or high-load conditions. The multilevel topology reduces voltage stress on semiconductor devices, lowers switching losses, and improves overall efficiency compared to conventional two-level converters. A closed-loop control strategy governs the converter operation. The DC bus

voltage is regulated by an outer voltage control loop that generates a reference current for the inner current loop. Proportional–integral (PI) controllers are used to ensure accurate tracking and stable operation. Additionally, a voltage balancing mechanism maintains equal voltage levels between the positive and negative rails, particularly under unbalanced loading.

The controller also monitors the battery state of charge (SOC) to coordinate smooth transitions between charging and discharging modes. The system design emphasizes efficient energy management, reliable bidirectional power transfer, and robust microgrid operation under varying renewable generation and load conditions. Simulation studies are performed to validate the design, confirming improved voltage regulation, dynamic response, energy efficiency, and overall reliability of the bi-polar DC microgrid.

7. Matlab/Simulink Model

The three-level bidirectional buck–boost converter system is modeled and simulated in MATLAB/Simulink to evaluate its performance in a bi-polar DC microgrid. The model includes renewable energy sources, the bi-polar DC bus, loads, a battery energy storage system (BESS), the three-level converter, and the closed-loop control system. Solar PV and wind generation are represented using controlled DC voltage/current sources with fluctuating outputs to emulate real- world renewable intermittency. The loads are modeled as variable DC resistive and constant power loads to test system response under different operating conditions.

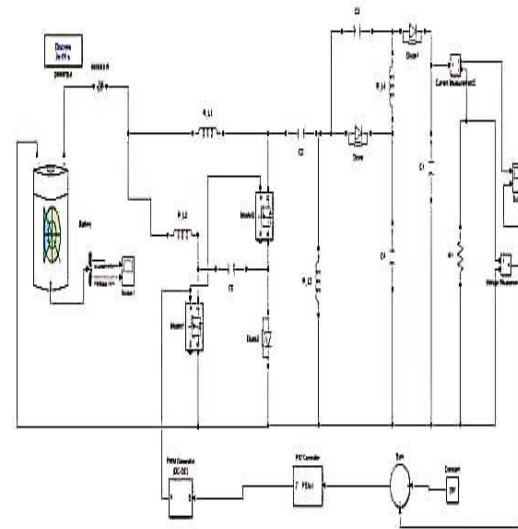

Figure 2: MATLAB Simulation Model

The three-level bidirectional converter is implemented using ideal IGBTs and diodes arranged in a neutral-point-clamped topology to reduce voltage stress on switching devices. Pulse-width modulation (PWM) signals generated by the controller manage the switching states to achieve bidirectional power flow. The control system consists of an outer voltage control loop that regulates the DC bus voltage and an inner current control loop that ensures accurate current tracking. Proportional–Integral (PI) controllers are used for both loops, while a voltage balancing algorithm maintains equal voltage distribution across the positive and negative DC rails. The battery model is integrated to simulate charging and discharging cycles based on the state of charge (SOC) and DC bus conditions.

Mode transitions between charging and discharging are dynamically managed by the controller, ensuring smooth operation under varying load and renewable generation. Key performance metrics such as DC bus voltage stability, current tracking, power flow, and voltage balance are monitored. The

simulation results validate the effectiveness of the proposed control strategy and demonstrate improved dynamic response, energy efficiency, and reliability of the bi-polar DC microgrid system. Overall, the MATLAB/Simulink simulation framework provides a comprehensive and realistic platform for analyzing the proposed system. The obtained results confirm the suitability of the three-level bidirectional converter for practical bi-polar DC microgrid applications, particularly in scenarios with high renewable penetration and frequent load variations, ensuring secure and stable system operation.

8. Simulation Results

The proposed three-level bidirectional DC-DC converter integrated with a battery energy storage system (BESS) was extensively simulated in MATLAB/Simulink to evaluate its performance under variable renewable energy generation and dynamic load conditions in a bi-polar DC microgrid. The simulation results clearly demonstrate the effectiveness and robustness of the proposed control strategy and converter topology.

Throughout the operating scenarios, the DC bus voltage remains tightly regulated at its reference value, despite fluctuations in renewable power input and sudden load variations. Smooth and seamless transitions between battery charging (buck mode) and discharging (boost mode) are observed, indicating stable bidirectional power flow without oscillations or voltage spikes. This confirms the converter's capability to support both energy storage and power supply functions within the microgrid. An important feature of the proposed system is its ability to maintain voltage balance between the positive

and negative DC rails.

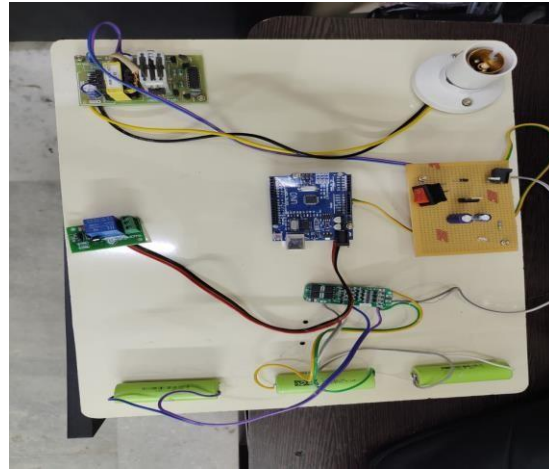

Figure 2: MATLAB Simulation Model

Even under unbalanced load conditions, the voltage difference between the two rails is effectively minimized, ensuring reliable operation of sensitive DC loads and improving overall system stability. This rail voltage balancing performance highlights the advantage of the three-level converter topology compared to conventional two-level structures.

The battery current closely tracks its reference value in both charging and discharging modes, validating the accuracy and responsiveness of the implemented current control loop. Proper current regulation ensures safe battery operation, prevents overcurrent stress, and enhances the lifespan of the energy storage system. Additionally, the system exhibits fast dynamic response to sudden load changes, with minimal overshoot and quick settling to steady-state values. Overall, the simulation results confirm that the proposed three-level bidirectional converter with BESS offers improved efficiency, enhanced voltage stability, and high reliability for bi-polar DC

microgrid applications. Its strong dynamic performance and effective voltage balancing make it well suited for modern DC distribution systems with high penetration of renewable energy sources.

9. Conclusion

This paper presents the control and integration of a three-level bidirectional buck–boost converter with a battery energy storage system in a bi-polar DC microgrid. The proposed system effectively manages bidirectional power flow, maintains DC bus voltage stability, and balances voltages across the positive and negative rails. Simulation results demonstrate fast dynamic response, accurate current tracking, and reliable operation under varying renewable generation and load conditions. Compared to conventional two-level converters, the three-level topology reduces voltage stress, improves efficiency, and enhances overall system performance. The study confirms that the proposed design provides a robust and efficient solution for energy management and stable operation in modern bi-polar DC microgrids.

10. FUTURE SCOPE

The proposed system can be extended and improved in several ways. Advanced control techniques such as model predictive control, adaptive control, or artificial intelligence-based controllers can be implemented to further enhance dynamic performance and robustness. Hardware-in-the-loop (HIL) testing and experimental validation can be carried out to verify real-world feasibility. Integration of multiple battery systems and supercapacitors can improve energy storage

flexibility and fast response. The system can also be adapted for hybrid AC/DC microgrids or large-scale renewable integration. Additionally, optimization of converter design for reduced cost, higher efficiency, and fault-tolerant operation can further enhance practical applicability in modern smart grids.

References

- [1] L. Xu, J. M. Guerrero, and X. Zhang, “Control strategies of bidirectional DC–DC converters for battery energy storage in DC microgrids: A review,” *IEEE Trans. Power Electron.*, vol. 36, no. 6, pp. 6789–6803, Jun. 2021.
- [2] F. Blaabjerg, Z. Chen, and S. B. Kjaer, “Power electronics as efficient interface in dispersed power generation systems,” *IEEE Trans. Power Electron.*, vol. 19, no. 5, pp. 1184–1194, Sep. 2004.
- [3] H. Mokhtari, M. G. Simoes, and J. L. Duarte, “Modeling and control of three-level bidirectional DC–DC converters for energy storage applications,” *IEEE Trans. Ind. Electron.*, vol. 61, no. 10, pp. 5550–5560, Oct. 2014.
- [4] R. C. Bansal and M. K. Mishra, *DC Microgrids: Control, Protection, and Stability*, Springer, 2019.
- [5] J. Sun, W. Liu, and Y. Li, “Bi-polar DC microgrid with battery storage and renewable integration: Control and simulation,” *Renew. Energy*, vol. 145, pp. 1203–1214, Jan. 2020.
- [6] A. K. Rathore, S. Jain, and V. Agarwal, “Multilevel bidirectional DC–DC converters for energy storage applications,” *Int. J. Electr. Power Energy Syst.*, vol. 123, pp. 106288, Feb. 2021.

- [7] Norambuena M, Kouro S, Dieckerhoff S, Rodriguez J. Reduced multilevel converter: a novel multilevel converter with a reduced number of active switches. *IEEE Trans Ind Electron.* 2018;65:3636- 3645.
- [8] Lakshmi M, Hemamalini S. Nonisolated high gain DC–DC converter for dc microgrids. *IEEE Trans Ind Electron.* 2018;65: 1205-1212.
- [9] Liu Y-C, Chen Y-M. A systematic approach to synthesizing multi-input DC–DC converters. *IEEE Trans Power Electron.* 2009;24:116-127.
- [10] Kardan F, Alizadeh R, Banaei MR. A new three input DC/DC converter for hybrid PV/FC/battery applications. *IEEE J Emerg Sel Topics Power Electron.* Vol 5. *IEEE;* 2017:1771-1778.
- [11] Azizi M, Mohamadian M, Beiranvand R. A new family of multi-input converters based on three switches leg. *IEEE Trans Ind Electron.* 2016;63:6812-6822.
- [12] Hawke JT, Krishnamoorthy HS, Enjeti PN. A family of new multiport power-sharing converter topologies for large grid-connected fuel cells. *IEEE J Emerg Sel Topics Power Electron.* 2014;2:962-971.
- [13] Prabhala VAK, Fajri P, Gouribhatla VSP, Baddipadiga BP, Ferdowsi M. A DC–DC converter with high voltage gain and two input boost stages. *IEEE Trans Power Electron.* 2016;31: 4206-4215.
- [14] Grbovic PJ, Delarue P, Le Moigne P, Bartholomeus P. A bidirectional three-level DC–DC converter for the ultracapacitor applications. *IEEE Trans Ind Electron.* 2010;57:3415-3430.
- [15] Grbovic PJ, Delarue P, Le Moigne P, Bartholomeus P. The ultracapacitor-based regenerative controlled electric drives with power- smoothing capability. *IEEE Trans Ind Electron.* 2012;59:4511-4522.